

Pro'sKit®

SS-331 LCD Desoldering Station



User's Manual
3RD Edition,

©2018 Copyright by Prokit's Industries Co., Ltd.

Description

SS-331 designed for lead free desoldering especially. The quick heating and strong power are for convenient and clear soldering / desoldering all types of DIP components.

Reasonable structure, single hand operation and strong absorbing power can be easy removal of the residual solder from the one-sided or two sided of the PCB.

This tool is used in the fields of electronic research, teaching and production, especially in the repairing and desoldering on the electronic appliances and communication equipments.

1. Control Unit



The desoldering iron gun is controlled automatically by the micro-processor. The digital control electronics and high-quality sensor and heat exchange system guarantee precise temperature control at the soldering tip. The highest degree of temperature precision and optimal dynamic thermal behavior under load conditions is obtained by the quick and accurate recording of the measured values in a closed control circuit, and this design is especially for the lead-free production techniques.

2. Desoldering Iron gun (5SS-331N-DG)

Desoldering iron gun with a power of 90W and a wide spectrum of soldering tips can be used anywhere in the electronics field.

The high power and gun type design make this iron gun suitable for fine desoldering work. The heating element is made of ceramic and the sensor on the desoldering tip can control the desoldering temperature quickly and accurately.

Technical Specification

Model No.	SS-331B	SS-331H	SS-331E
Voltage	220V-240V~ 50Hz		120V~ 60Hz
Soldering Power	90W		
Power Consumption	140W		
Temperature	160°C ~ 480°C		
Vacuum Pressure	>600mm Hg		
Heating Element	Ceramic Heater		
Sleep mode	Approximately 10 minutes if not use		
Accessories	Spare tip x 3 (∅ 1.2(on the gun)∅1.0/ ∅ 1.5mm) Cleaning tool x 3 (∅0.7/∅0.9/∅ 1.2mm) Filter sponge x 4 (φ20.8x1 +φ16.8x3)		
Certificate	CE, RoHS	RoHS	cTUVus, RoHS
Plug			
Station Size (mm)	172 x 135 x 190		
Weight (kgs)	1.6		

Operating Instruction

1. Place the desoldering iron gun in the holder separately. Then connect the plug to the receptacle on the station and turn clockwise to tighten the plug nut. Check that the power supply is corresponding to the specification on the type plate and the power switch is on the "OFF" position. Connect the control unit to the power supply and switch on the power. Then a self-test is carried out in which all display elements are switched on briefly. The electronic system then switches on automatically to the set temperature and displays this value.
2. If not use for about 10 minutes ,the desolering station will be automatically into sleeping mode and the temperature is reduced to 200 C, this for prolonged the life of the suction nozzle and the heating element; Shake or pick up the desoldering Iron gun, can start the working again.
3. The display and temperature setting

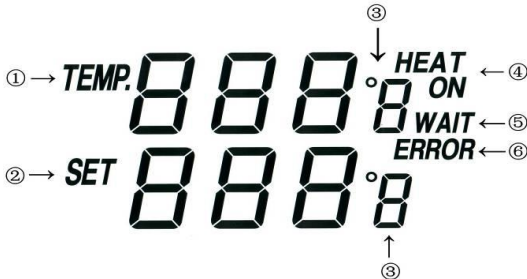

- ①. Shows the actual temperature of the desoldering tip.
- ②. Shows the setting temperature: Pressing the "UP" or "DOWN" button can switch the digital display to the set point display. The set-point can be changed for $\pm 1^{\circ}\text{C}$ by tapping the "UP" or "DOWN" button. Pressing the button will change the set-point quickly. The digital display will return automatically to the actual value and the iron will reach to the setting temperature quickly.
- ③. $^{\circ}\text{C}/^{\circ}\text{F}$ display: Switching the temperature display from $^{\circ}\text{C}$ to $^{\circ}\text{F}$ by pressing the "*" button and then the electronic system will display the actual temperature① and setting temperature② in $^{\circ}\text{F}$, and vice versa.
- ④. When the actual temperature on the desoldering tip is less than the set-point, "HEAT ON" will display and make the desoldering tip heating up.
- ⑤. When the absolute offset is more than $\pm 10^{\circ}\text{C}$ between the actual temperature and the set-point on the desoldering tip or the nozzle, "WAIT" will display. It means that the temperature electronic control system is not in the stable situation, we should wait a moment to let the "WAIT" disappear.
- ⑥. When "----" & "ERROR" display, there may be a trouble on the system, or the desoldering iron gun is not connected to the control system correctly.

Safety Instruction

1. The manufacturer assumes no liability for uses other than those described in the operating instructions or for unauthorized alterations.
2. The operating instructions and cautions should be read carefully and kept in an easily visible location in the vicinity of the control system. Non-observance of the cautions will result in accidents, injury or risks to health.

Caution

1. The power cord only can be inserted in approved power sockets or adapters.
2. High Temperature

When the temperature of the desoldering tip will reach as high as around 400°C (752 °F) When the power switch is on. Since mishandling may lead to burns and fire, be sure to comply with the following precautions:

 - A. Do not touch metallic parts near the desoldering tip/ nozzle.
 - B. Do not use this system near the flammable items.
 - C. Advise other people in the work area that the unit can reach a very high temperature and should be considered potentially dangerous.
 - D. Turn off the power switch while taking breaks and when finishing using.
 - E. Before replacing parts or storing the system, turn off the power and let it cool down to the room temperature.
 - F. Warning: this tool must be placed on its stand when not in use.
 - G. A fire may result if the appliance is not used with care, therefore:
 - a) Be careful when using the appliance in places where there is combustible material.
 - b) Do not apply to the same place for a long time.
 - c) Do not use in presence of an explosive atmosphere.
 - d) Be aware heat may be conducted to combustible materials that out of sight.
 - e) Place the appliance on its stand after use and allow it to cool down before storage.
 - f) Do not leave the appliance unattended when it is switched on.
3. Take care of your tools

Do not use the tools for any applications other than desoldering.
Do not rap the iron against the work bench or otherwise subject the iron to severe shocks.
Do not file the desoldering tip to remove the oxide, please wipe the tip on the cleaning sponge.
Use only accessories or attachments which are listed in the operation manual.
Use of other tools and other accessories can lead to a danger of injury.
Please turn off the power before connecting or disconnecting the desoldering iron gun.
4. Maintenance
 - 4.1 Before further use, safety devices or slightly damaged parts must be carefully checked for error-free and intended operation.
 - 4.2 Inspect moving parts for error-free operation and that they don't bind, or whether any parts are damaged.
 - 4.3 Damaged safety devices and parts must be repaired or replaced by a qualified technician, so long as nothing else is indicated in the operation manual.
 - 4.4 Use only accessories or attachments which are listed in the operation manual. Use of other tools and other accessories can lead to a danger of injury.

5. Keep children at a distance

Warning: this appliance is not intended for use by young children and infirm persons unless they have been adequately supervised by a responsible person to ensure that they can use the appliance safely.

Warning: Young children should be supervised to ensure that they do not play with the appliance.

Unused desoldering station should be stored in a dry location which is out of the reach of children. Switch off all unused desoldering station.

6. Protect yourself against electrical shocks
Avoid touching grounded parts with your body, e.g. pipes, heating radiators and so on. The grip of antistatic designed desoldering tool is conductive.
7. Work environment
Do not use the desoldering station in a moist or wet environment. The desoldering iron gun should be placed on the holder after finished using.
8. Observe the valid safety regulations at your work place.

Desoldering Gun Maintenance

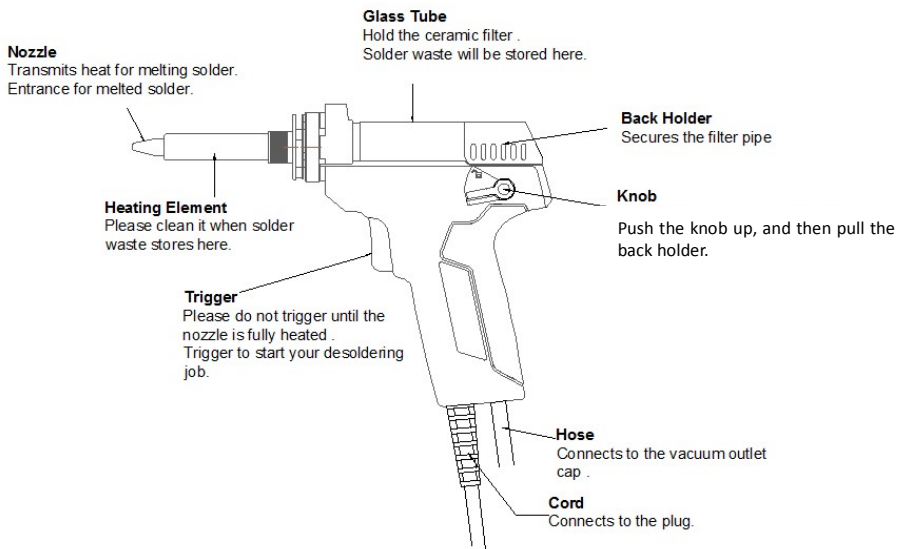

WARNINGS:

1. To avoid injury or damage the items, do not touch the metallic parts near the nozzle, and do not use this system near the flammable items.
2. Remove the power plug before performing maintenance procedure, except doing the nozzle and heating element clean process.
3. If the pump does not operate, immediately clean the nozzle & heating element, and replace the filter

- In the high temperature, the solder waste will get oxidized(lead free solder's melting point is 220°C , non-lead free solder's melting point is 180°C),swelled and stuck on the inner wall tightly, If it did not clean after use, the solder waste will block the desoldering gun, can not remove even use cleaning pin.

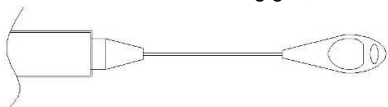

(Cleaning pin)

Please follow below steps to remove the solder waste:

- Push the knob up, and then pull the back holder.

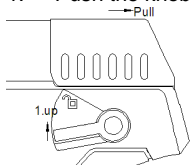

- Take the spring out from the glass tube ,then remove the solder waste

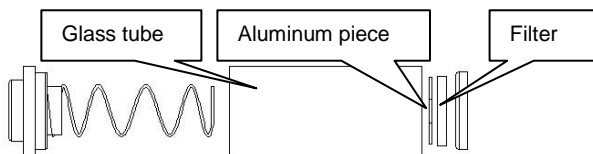

Put the spring back to glass tube, then put glass tube back to position.Press the back holder, then the knob will bullet down and become locked automatically .

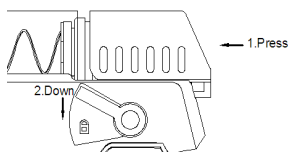

INSTRUCTIONS:

- After each operation is finished, please idling suck the desoldering gun 3-5 times soon, this can clean the solder waste inside the pipe.
- If the operation interval is about 20 minutes, after idling sucking the desoldering gun, please also use the cleaning tool to clean the pipe.
- When you find the desoldering efficiency gets down, please use the cleaning Pin to clean the pipe immediately.
- If the operation interval is long, we advise to adjust the temperature to about 200°C . When you use it again, you can adjust to the working temperature,
- When the glass tube has absorbed about 1/2 solder waste, please clean it immediately. When you find the filter is getting hardened, please replace the filter immediately.

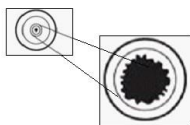

The Nozzle hole will get enlarged with corrosion.

CAUTION

The Nozzle hole will get enlarged with corrosion, but such phenomena can not be noticed easily. Therefore, if desoldering efficiency goes down and all other parts appear to be OK, the nozzle is probably eroded and should be replaced.

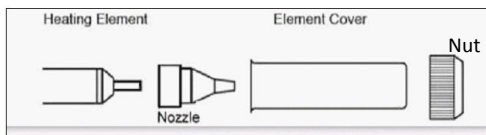

Troubleshooting

Fault phenomenon	Failure cause	solution
LCD No display	Fail to connect power source	Check the power cord connection and plug in the power cord to power Jack.
	Fuse blown	Replace fuse : 3.15A / 250V
Fail to Set temperature	Key damage	Return to dealer
Suction non-action	Trigger switch damage	Return to dealer
	Motor damage	Return to dealer
Nozzle is not hot	Heating element damaged	Return to dealer
	internal wire damage	Return to dealer
Can not melt solder	Unreasonable setting of temperature	Reset the appropriate temperature
	nozzle oxidation	Replace nozzle
	nozzle is not hot	Return to dealer
Suction ability is low	Blow- by	Check the connection of vacuum outlet Check the installation of glass tube
	Excessive solder waste storage in glass tube	Removing solder waste from glass tube
	Filter degradation	Replacement of filter
	Air pump bad	Return to dealer
Unable to absorb solder	solder hole blocked	under heating condition, using cleaning pin to clean heating element
	Solder melt inadequately	when solder is completely melted
Tin absorption hole blocked, can not be dredged	Solder waste accumulate at the end of heating element	Take off the glass tube, use the soldering iron to heat the steel pipe back to remove the solder waste, and then use the cleaning pin to dredge.

Checking the heating element:

Disconnect the plug and measure the resistance value between the desoldering gun connecting plug pins as follows.



a. Between pins 1 & 2 (Sensor)	50Ω±3Ω (25°C room temperature)
b. Between pins 3 & 4 (Heating Element)	2Ω±1Ω (25°C room temperature)
c. Between pin 5 & 6	0Ω (tigger on)
d. Between pin 7 & 2	open or 0Ω(shaking gun)

If the resistance values of 'a' and 'b' are outside the above value, replace the heating element (sensor).

If the resistance values of 'd' is outside the above value, Sleep mode was lose efficacy

Replace the heating element:

- 1) Disconnect the power plug, wait unit the desoldering gun temperature down to room temperature.
- 2) Loosen screws and disassemble desoldering gun.
- 3) Cut off the wire of heating element, prepare a new heating element (model no. 5SS-331N-H).as follow figure.



- 4) Connect heating element :

Put the heating element on the black heating element holder, insert the heat shrink tube (Φ3x25mm) and metal tube (Φ2x6mm) to the wire, connect wire and pull the metal tube to the connect position, crimping the metal tube with crimper tool, pull the heat shrink tub to the metal tube and heating.

- Long blue wire (ground) connects to the yellow wire in handle
- Two white wires (heating element) connect to the two red wire, no need to distinguish positive electrode and negative electrode.



- Two blue wires (Sensor) connect to the black and blue wire in handle, no need to distinguish positive electrode and negative electrode.
 - Any one wire connect to the Sleep control sensor
- 5) Measure the resistance value again, make sure the value is correct. Short the desoldering gun nozzle and shell of plug, and the resistance value should be 0Ω.
 - 6) Assembly desoldering gun again, do not press the wire or put into the wrong position.

Note : The color of wire for reference, color change without notice.

Any repair or replacement operation by professional operator

Pro'sKit[®] SS-331 数显吸焊台使用手册



警告！ 为降低伤害风险，用户必须阅读 使用手册

概述

SS-331 特别为无铅吸焊而设计。快速升温和大功率的特点使其可以方便快速的焊接/拆焊所有类型的 DIP 元器件。

合理的结构，单手操作和强大的吸焊功率能够轻松的从 PCB 一面或两面除去残余锡渣。

目前已广泛的应用于电子科研，教学以及生产等单位，特别是家电维修和通讯器材维修人员所不可缺少的首选专用工具。

1.控制单元

吸焊枪由微处理器自动控制。数字控制装置和高质量的传感器及加热交换系统，保证对吸焊烙铁头的温度进行精确的控制。通过快速准确的记录闭合控制回路测量，可以获得较高的温度精度和带负载状况下最佳热量传递性能，特别适合用于无铅制程工艺。

2.吸焊枪 (5SS-331N-DG)

吸焊枪的功率为 90W，可以配各种尺寸的吸焊烙铁头，广泛应用于电子领域。

大功率和细长外形设计适合狭窄空间内除去残余锡渣操作，发热芯采用陶瓷发热材料制作，顶端温度传感器特点在于能够快速并准确的控制吸焊烙铁头温度。

技术规范.

型号	SS-331B	SS-331H	SS-331E
电压	220V-240V~ 50Hz		120V~ 60Hz
吸焊枪功率	90W		
整机功率	140W		
温度	160°C ~ 480°C		
真空吸力	>600mm Hg		
发热组件	陶瓷发热芯		
休眠	不使用 10 分钟		
配件	吸嘴 x 3(∅1.2(装在吸枪上)∅1.0/ ∅ 1.5mm) 通针 x 3(∅ 0.7/ ∅ 0.9/ ∅ 1.2mm) 过滤棉 x 4 (∅ 20.8mm x1 + ∅ 16.8mm x3)		
认证	CE, RoHS	RoHS	cTUVus, RoHS
插头			
尺寸(mm)	172 x 135 x 190		
重量(kg)	1.6		

操作说明：

1. 将吸焊枪放置在支架上。然后将插头插入插座顺时针方向锁紧螺母。检查供电电源符合本产品的规格并确认总电源开关处于 **OFF** 的位置。接通控制系统的电源并打开电源开关。系统进行自检，所有的液晶显示都暂时被点亮。电子系统自动打开并迅速达到设定的温度值。搁置架内放置约 10 分钟后自动进入休眠状态，温度降低到 200℃，可延长吸嘴及发热芯使用寿命。晃动或拿起吸锡枪即可激活至工作状态；
2. 显示屏和温度设置：



数字显示说明：

- ①显示吸焊烙铁头的实际温度。
 - ②显示的是设定温度，通过按“UP”或“DOWN”键来改变设定值。轻压单下“UP”或“DOWN”键设定值将以 $\pm 1^{\circ}\text{C}$ 变化，持续按下“UP”或“DOWN”键设定值将会快速改变。改变设定值后，电子系统自动工作，显示温度会迅速到达设定值。
 - ③ $^{\circ}\text{C}$ 或 $^{\circ}\text{F}$ 温度，通过按“*”按钮切换摄氏或华氏温度，切换后电子系统会自动显示的摄氏或华氏实际温度①和设定温度②数值。
 - ④当吸焊烙铁头实际温度小于设定温度时显示“HEAT ON”表示电子系统对烙铁正在加热。
 - ⑤当吸焊烙铁头实际温度与设定温度的绝对偏差大于 $\pm 10^{\circ}\text{C}$ 时显示“WAIT”，表示电子控温系统还没到达稳定状态，请稍做等待，待“WAIT”不显示时即可正常使用了。
 - ⑥显示“---”及 ERROR 闪烁则表示系统有故障，或者是吸焊枪没有正确连接到控制系统。
3. 安全操作说明

3.1 制造商对于超出操作说明中所到的其他使用或未经授权的更改，不负任何责任。

3.2 应仔细阅读操作说明及警告并将其放置在控制系统附近，如不遵守这些警告，将有可能发生意外事故，人体伤害或健康伤害。

4 警告及注意事项

4.1 电源线只能插入经认证的电源插座或适配器中。

4.2 小心高温:在开机状态下，吸焊烙铁头的温度可以达到大约 400℃ (752°F) 左右，由于不正确的操作可能会造成烧伤或引起火灾，故应确保遵守以下预防措施：

- 不要让金属部件接触到吸焊烙铁头；
- 不要在易燃物品附近使用该系统；
- 告知工作区域中的其他人员此设备会达到非常高的温度应注意识别其潜在的危险性；
- 在休息及使用完后应关闭总电源
- 在更换零件或储存前，应关闭总电源并让其冷却到室温
- **警告：不用时一定要将此工具放置在特定的支架上。**
- 如使用不当可能会引起火灾，因此
 - 在有易燃物品的场所使用该设备一定要小心；
 - 不要长时间在同一位置使用该设备；
 - 不要在有爆炸性气体的场所使用；
 - 要知道热量有可能会引燃不在视线范围内的可燃物质；
 - 使用完后要将器具放置在特定的支架上，且要在冷却后方可收藏起来；
 - 离开时必须关闭电源开关。

4.3 爱护工具

- 不要将此设备用于吸锡以外的其他操作。
- 不要在工作台上敲打吸焊枪或其他严重的撞击。
- 不要锤吸焊烙铁头上的氧化层，请使用浸水的清洁棉擦除氧化层。
- 吸焊烙铁头如被异物堵塞，请利用所配合规格通针在吸焊枪加热状态下进行清理。
- 请不要长时间设置较高的温度，容易造成吸焊烙铁头氧化加速老化。
- 确保使用操作说明上列明的附件或配件，使用其他的工具或其他配件使本系统损坏或会有受伤的危险。
- 在接通或断开吸焊枪前应先关闭电源。

4.4 工具保养

在使用前，应仔细检查安全装置或有轻微损害的零件无故障及在指定操作状态。

4.4.1 检查活动的零件无故障操作，并且没有绕线及零件损坏。

4.4.2 已损坏的安全设备及零件都应由有资格的专业人员进行维修或更换。

4.4.3 只使用操作说明中列出的配件，如果使用其他工具或配件有可能对操作人员造成伤害。

4.4.4 放置在儿童接触不到的地方

警告：老人和儿童必须在监护人在场确保可安全使用的情况下，方可使用该设备。

警告：应确保儿童在没有监护的情况下，无法接触到该设备。

4.4.5 不用时应存放在干燥的，儿童接触不到的地方。

4.5 避免遭受电击

4.6 避免用身体接触接地零件，如：吸焊枪管等。

4.7 不要在潮湿的环境中使用焊接工具。吸焊枪用完后要放回到支架上。

4.8 遵守工作场所中的安全操作规定。

锡焊枪使用与维护

吸嘴

快速导热并吸入融锡

透明吸锡槽

清楚检视锡渣状况，清洁容易

陶瓷发热芯

升温快速

扳机

请于吸嘴加热至指定温度时，再按压扳机开始工作

后盖

固定套管

安全锁扣

将旋钮上移，解除锁定，再将后盖往后拉

软管

连接至真空盖出口

防烫电源线

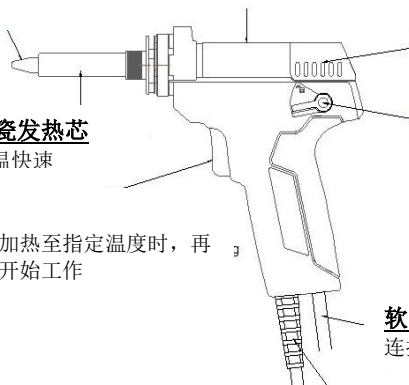

警告：

1. 为避免人身伤害或损坏物品，请勿触摸喷嘴附近的金属部件，也不要再在易燃物品附近使用本系统。
2. 在执行维护程序之前，请拔下电源插头，但吸嘴和加热组件清洁过程除外。
3. 如果气泵不工作，请立即清洁吸嘴、加热组件和过滤棉，必要时更换之。
4. 在高温时焊料会被氧化(无铅焊料的熔点为 220℃，含铅焊料的熔点为 180℃)，膨胀并粘在内壁上，如果使用后未做清洁，焊料将堵塞拆焊枪，即使用通针清洁也无法清除。



清洁通针

请按照以下步骤进行移除焊接锡料:

1. 将旋钮上移，解除锁定，再将后盖往后拉。

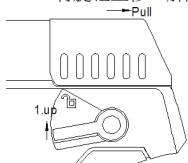

2. 将弹簧自透明吸锡槽内取出，移除焊接锡料。



3. 将弹簧放回透明吸锡槽内，将透明吸锡槽装回原位。
将后盖往前推，旋钮将会往下压并自动锁定。

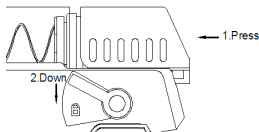

注意事项：

- 1、每次工作后。建议空吸 3-5 次，清空发热钢管内残锡。
- 2、如果使用间隔 20 分钟左右，建议空吸后，再用通针清理钢管。
- 3、在使用过程中发现吸力减弱，请用通针清理钢管。
- 4、若使用频率很低，建议把锡枪调至 200℃ 左右，使用时再调至工作温度。
- 5、透明吸锡槽内锡渣应及时清理，当发现过滤棉有硬化状态，需及时更换。
- 6、透明吸锡槽为耐高温石英管，属于易碎材质，请勿用力磕碰。

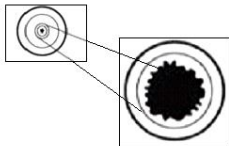

吸嘴孔因腐蚀而变大

注意:

吸嘴孔会因腐蚀而扩大,但这种现象不容易被发现,因此,如果拆焊效率下降且所有其他部件看起来都没问题,则吸嘴可能已被侵蚀,需要更换

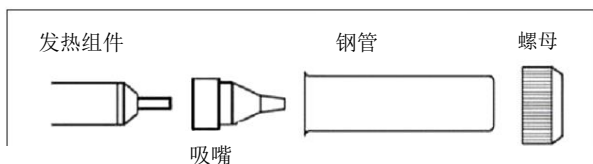

故障排除

故障现象	故障原因	解决方法
LCD 不显示	电源未连接	检查电源线连接,插接好电源线与电源插口。
	保险管损坏	更换保险丝管,规格:3.15A/250V
无法设定温度	按键损坏	退回经销商维修
吸力不动作	扳机开关损坏	退回经销商维修
	马达损坏	退回经销商维修
吸嘴不发热	发热芯损坏	退回经销商维修
	吸枪连接线损坏	退回经销商维修
不熔锡	温度设定不合理	重新设定合适温度
	吸嘴氧化	更换吸嘴
	吸头无温度	退回经销商维修
吸力不足	漏气	检查吸锡枪与主机端口。 检查透明吸锡槽安装。
	吸锡槽里面储锡过多	拆掉锡筒去除里面锡渣
	过滤棉老化	更换过滤棉
	气泵不良	退回经销商维修
无法吸锡	吸锡孔堵塞	使用通针在加热状况下疏通。
	熔锡不充分	吸锡时待锡全熔开后再吸锡
吸锡孔堵塞无法疏通	吸渣堆积尾端	取下玻璃套管,使用烙铁在钢管后端加热把锡化掉,再使用通针疏通。

发热芯更换：



插头标识

a. 1 & 2 (传感器)	50Ω±3Ω (25℃ 室温)
b. 3 & 4 (发热器件)	2Ω±1Ω (25℃ 室温)
c. 5 & 6 (吸枪开关)	0Ω (按下开关)
d. 7 & 2 (休眠开关)	开路或 0Ω (晃动锡枪)

发热芯检查（使用电表欧姆档检测）：

- 1) 插头 3-4 脚(发热丝): 2Ω±1Ω(25℃ 环境)； 2) 插头 1-2 脚（传感器）: 50Ω±3Ω；
检测以上符合，则判断发热芯正常，若不符合，则需要更换维修。
- 3) 插头 5-6 脚：与控制开关连接,按下开关后: 0Ω；
- 4) 若插头 7-2 脚检测情况不符合上表，则感测器件不良，需要更换，但不涉及发热芯。

更换作业步骤:

- 1) 更换作业必须断开电源线，确保吸锡枪头部温度已经降至环境温度；
- 2) 拆开吸锡枪手柄外壳及发热芯固定螺丝；
- 3) 剪断损毁的发热芯引线，准备预备更换的发热芯（型号：5SS-331N-H）；如图：



4) 发热芯接线方式：

更换发热芯前先将发热芯与黑色胶木固定好后再进行接线，接线前先将热缩套管（Φ3x25mm）及压接铜套管(Φ2x6mm)插入，对线连接后用压接钳固定压接铜套管，将热缩管移动至接线裸露位置加热，完成接线动作。如图示意：



- 长蓝线（接地线）接手柄内黄色粗线；
- 两根短白线（发热丝）接手柄内红色线，不分正负极；
- 两根短蓝线（测温传感器）接手柄内细黑/蓝色线，不分正负极；其中任何一根接线与控制休眠感测器端进行连接。

5) 按照发热芯检查方式再次检查各连接情况，另外航空插头金属外壳与烙铁头应该短路为 0Ω；

6) 装回固定螺丝复位，安装时注意电线走向，不能抵触螺丝孔或被外壳压伤；

注：电线颜色供参考，变更颜色不另行通知。维修更换请专业人员操作；

Pro'sKit® 中国地区产品保固卡

购买日期		店章
公司名称		
联络电话		
电子邮箱		
联络地址		
产品型号	SS-331H	

- ※ 在正常使用情况下，自原购买日起主机保修一年（不含配件、易耗品）。
 - ※ 产品保固卡需盖上店章、日期章并填写产品序号，其保固效力始生效。
 - ※ 本卡请妥善保存，如需维修服务时，请同时出示本保固卡，如无法出示，视为自动放弃。
 - ※ 保固期满后，如需维修之性质，则酌收检修工时费用。若有零件需更换，则零件费另计。
- 保修说明

一、 保固期限内，如发生下列情况，本公司需依实际状况酌收材料成本或修理费(由本公司维修人员判定):

- 产品表面的损伤，包括外壳的破裂或刮痕
- 因误用、疏忽、不当安装或测试，未经授权私自打开产品修理，修改产品或者任何其它超出预期使用范围的原因所造成的损害
- 因意外因素或人为因素(包括搬运、挤压、碰撞、高温、输入不合适电压、腐蚀等不可抗力因素)导致的故障或损坏。
- 因使用非宝工导致的故障及损坏。

二、 非服务保障内容

- 本机主体外之配件：如发热芯,保险管,吸锡嘴, 过滤棉, 通针等配件。
- 任何因自然磨损、超负荷工作而引起的损坏。

三、 超过保固期限仍需检修，虽未更换零件，将依本公司保固条款酌收工时服务费用

制造商：宝工实业股份有限公司

地址：台湾新北市新店区民权路 130 巷 7 号 5 楼

电话：886-2-22183233

E-mail: pk@mail.prokits.com.tw

生产商：上海宝工工具有限公司

地址：上海市浦东新区康桥东路1365弄25号

原产地：中国 上海

销售公司：深圳畅联贸易有限公司

地址：深圳市福田区红荔西路上步工业区403栋东座5楼

电话：0755-83692415

传真：0755-83692143

400服务热线：400-1699-629

E-mail: shenzhen@mail.prokits.com.tw

Pro'sKit®

寶工實業股份有限公司
PROKIT'S INDUSTRIES CO., LTD.



<http://www.prokits.com.tw>

E-mail: pk@mail.prokits.com.tw

©2018 Prokit's Industries Co., LTD. All rights reserved 2018003C)